

PLASMA THRUSTERS

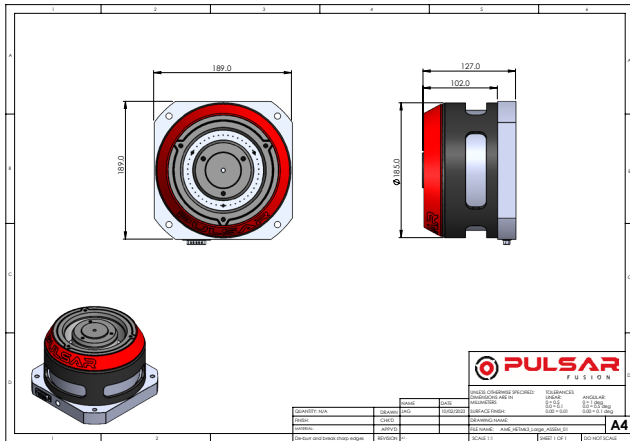

ORBITAL PLASMA THRUSTERS

20kW



PRODUCT DESCRIPTION

Pulsar Fusion have been developing Hall-effect thrusters (HET) technology since 2016. This is a type of ion thruster in which the propellant is accelerated by an electric field for in space propulsion. Hall Effect thrusters use a magnetic field to limit the electrons’ axial motion and then use them to ionize propellant, efficiently accelerate the ions to produce thrust, and neutralize the ions in the plume. Pulsars new range of Plasma Thrusters provide higher performances and in-space mission reliability and durability.

DEVELOPMENT

Pulsar Fusion has been awarded two significant supporting grants for its HET’s:- in 2021 the Southampton University ‘Sprint Grant’ which was delivered and completed, and in 2022 from the UK Space Agency (UKSA) to develop integrated Fission-based power systems for Electric Propulsion.

Pulsar Fusion continually look for development opportunities to enhance and optimise our range of electric plasma thrusters.

APPLICATION

Pulsar Fusion places great emphasis on long-lifetime, mission durability and flexibility. Our Hall Effect thrusters above 5kW are magnetically shielded for lifetimes beyond 20,000 hours. Thruster start-up and shut-down times are also of critical importance to us. Our state-of-the-art laboratory at Bletchley allows us to fine-tune the thrusters to your mission needs before putting them in to production.

Our thruster products can be used for an extensive in-space mission portfolio, such as multiple satellite deployments, space transportation, space debris management, In Situ Resource Utilisation (ISRU), Lunar and cislunar, In Orbit Servicing & Manufacturing (IOSM) and many other applications.

ADDITIONAL POWER RANGES

Pulsar Fusion can design and manufacture electric plasma thrusters over much lower power ratings than 1.5Kw. Please talk to us about your mission electric propulsion ranges and specifications. Please also refer to our 1.5kW and 5kW range data sheets.

PULSAR 20kW

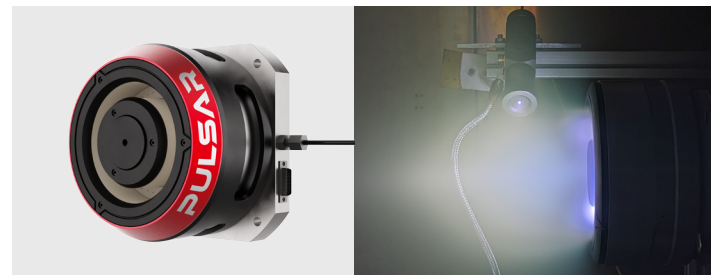

SPECIFICATIONS

Propellants	Ar, Kr, Xe	
Assembly Mass	43kg	
Dimensions	189 x 189 x 127mm	
Voltage	450V	600V
Current	14A	18.2A
Power*	15000W	20000W
Nominal Thrust	1010mN	
Specific Impulse	2025s	2700s
Estimated Total Impulse *(assumes 20000hrs life)	72MN	
Efficiency (%)	50	

* Clustering configurations available to 100kW

BESPOKE TESTING FACILITIES

Pulsar Fusion conducts extensive and bespoke performance and lifetime testing at our facility in Bletchley, UK. These facilities were developed with industrial and academic partners and is continually expanding and advancing as an electric propulsion centre of excellence.

We specialise in providing our customers with bespoke mission testing programmes. Pulsar’s experienced team of engineers and technicians provide you with accurate and reliable test and reliability results, and our facility is designed to meet all of your testing needs. With our advanced equipment and expert support, you can trust that your electric propulsion systems will be thoroughly tested and ready to perform at their best.

Pulsar has tested it’s HET’s for structural launch integrity on a vibration table at Harwell, UK in 2021. The thrusters successfully experienced 20GMRS which simulates the conditions of a most extreme launch.

